

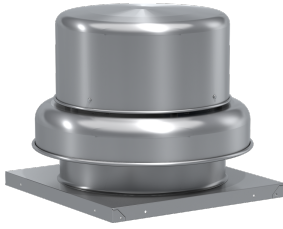

SKU  
GB-101-3X-QD-DR3

Job Name:  
Mark:  
Submitted By:  
Date: 07/14/2020

## Centrifugal Downblast Exhaust Fan, Model GB-101, Belt Drive, 1/3HP, 115/208-230V, 1Ph, Motor & Drives Unassembled, 733-1220 CFM



Model GB, belt drive centrifugal roof exhaust fans are designed to meet the general clean air exhaust requirements for industrial and commercial buildings. Units feature a fully rolled windband bead for increased stability and easy transport. Fresh outside air is drawn in under the motor cover to maximize motor life.

- Centrifugal wheel provides high-efficiency and minimal sound
- True vibration isolation supports the motor and wheel for long life and quiet operation
- One-piece aluminum curb cap provides a weather-tight fit
- Positive motor cooling with fresh air results in maximum motor life
- Galvanized birdscreen protects the fan discharge from birds and small objects
- Motor, pulleys and belt ship separately for field assembly

### Certifications

AMCA Sound & Air  
High Wind and Hurricane  
Seismic  
UL/cUL 705

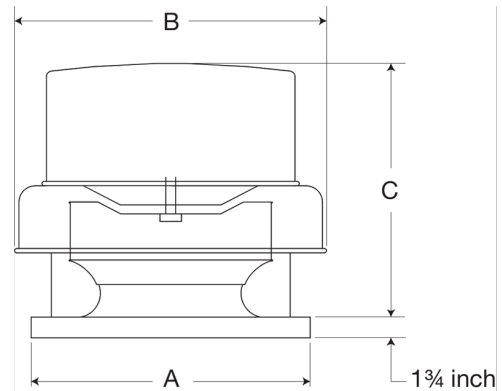

| A     | B         | C        |
|-------|-----------|----------|
| 19 in | 24.375 in | 23.75 in |

## Performance Characteristics

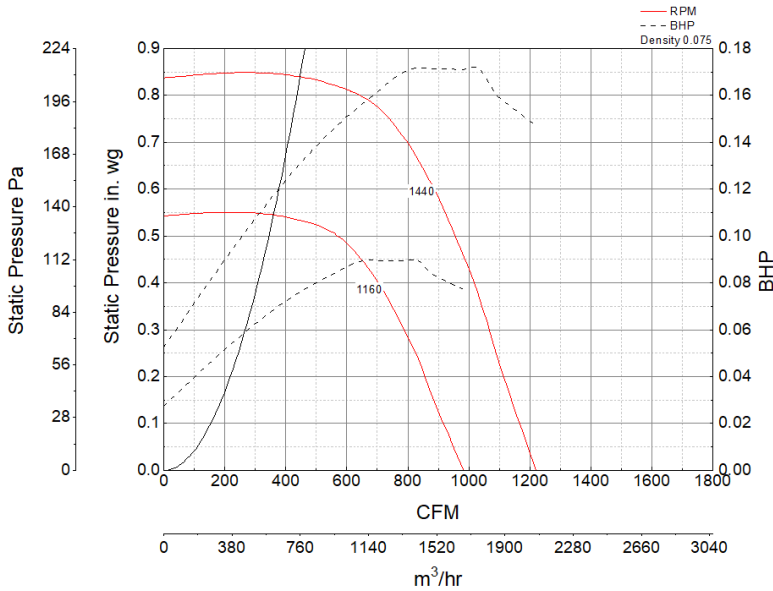

## Construction Features

|                           |  |
|---------------------------|--|
| Drive Type                | Belt Drive   |
| Impeller Type             | Centrifugal Wheel  |
| Impeller Material         | Aluminum   |
| Housing Material          | Spun Aluminum  |
| Includes                  | Disconnect switch<br>Unassembled drive package                       |
| Max Inlet Temp            | 180 °F   |
| Certifications            | AMCA Sound & Air<br>High Wind and Hurricane<br>Seismic<br>UL/cUL 705 |
| Drive Package Description | Motor and drives shipped loose                                       |
| Required Accessory        | Roof curb for new installations                                      |

## Motor Information

|                    |                   |
|--------------------|-------------------|
| Service Factor     | 1.35              |
| Phase              | 1                 |
| Voltage            | 115<br>208<br>230 |
| HP                 | 1/3               |
| Hertz              | 60                |
| Motor Enclosure    | Open Drip Proof   |
| RPM                | 1800              |
| Motor Insulation   | B                 |
| Thermal Protection | Auto              |
| Nominal Efficiency | 64                |
| NEMA Frame Size    | 48                |

## Air and Sound Performance

| Motor HP | Max BHP | Max Fan RPM | Min Fan RPM | Ps (in. wg) | 0     | 0.125 | 0.25  | 0.375 | 0.5 | 0.625 | 0.75 |
|----------|---------|-------------|-------------|-------------|-------|-------|-------|-------|-----|-------|------|
| 1/3      | 0.17    | 1440        | 1160        | CFM         | 1,220 | 1,153 | 1,089 | 1,031 | 954 | 865   | 733  |
|          |         |             |             | Sones       | 9.5   | 9     | 8.7   | 8.5   | 8.1 | 7.6   | 6.9  |



- Greenheck Fan Corporation certifies that the model shown herein is licensed to bear the AMCA Seal. The ratings shown are based on tests and procedures performed in accordance with AMCA Publication 211 and AMCA Publication 311 and comply with the requirements of the AMCA Certified Ratings Program.
- Performance certified is for installation type A: Free inlet, Free outlet.
- Power rating (BHP/kW) includes transmission losses.
- Performance ratings include the effects of birdscreen.
- The sound ratings shown are loudness values in fan sones at 5 ft. (1.5 m) in a hemispherical free field calculated per AMCA Standard 301. Values shown are for installation type A: free inlet hemispherical sone levels.

## California Residents

### ⚠ WARNING

This product can expose you to chemicals including cadmium used in the processing of corrosion resistant metal and fasteners, which is known to the State of California to cause cancer and birth defects or other reproductive harm. For more information visit [www.P65Warnings.ca.gov](http://www.P65Warnings.ca.gov)